



TP系列包络蜗轮蜗杆减速机  
TP worm reducer

**GELUFU**

**格鲁夫机械设备制造有限公司**  
Gelufu Machinery Equipment Manufacturing Co. Ltd

## 1 概述 >>>>>

平面包络环面蜗杆传动分为平面一次包络、平面二次包络两种，与圆柱蜗杆相比，环面蜗杆副同时工作齿数较多，承载能力大，传动效率高，使用寿命长，尤其适用于重载动力传动装置。

**TP**系列平面包络环面蜗杆减速器（JB/T9051-1999）为平面一次包络蜗杆传动，包括TPU、TPS、TPA型三种型式，适用于冶金、矿山、起重、运输、建筑、石油、化工、航天、航海设备或精密传动的减速传动。

工作条件：蜗杆转速不超过1500r/min；工作环境温度为-40-40℃，当工作环境温度为0℃以下时，启动前润滑油必须加热到0℃以上，或采用低凝固点的润滑油；当环境温度超过40℃时，需采取强迫冷却措施。

## 2 型号、中心距、传动比、标记示例 >>>>>

### 2.1 型号

- (1) **TPU**型—蜗杆在蜗轮之下平面包络环面蜗杆减速器；
- (2) **TPS**型—蜗杆在蜗轮之侧平面包络环面蜗杆减速器；
- (3) **TPA**型—蜗杆在蜗轮之上平面包络环面蜗杆减速器。

### 2.2 中心距

**TP**系列蜗杆减速器中心距a见下表。

中心距 a														
第一系列	100	125	-	160	-	200	-	250	-	315	-	400	-	500
第二系列	-	-	140	-	180	-	224	-	280	-	355	-	450	-

### 2.3 公称传动比

**TP**系列蜗杆减速器公称传动比i传动比见下表。

型号	TPU TPS TPA									
第一系列	10	12.5	16	20	25	31.5	40	50	63	
第二系列			14	18	22.4	28	35.5	45	56	

### 2.4 标记示例

**TP** U 200-10-II F JB/T 9051-1999

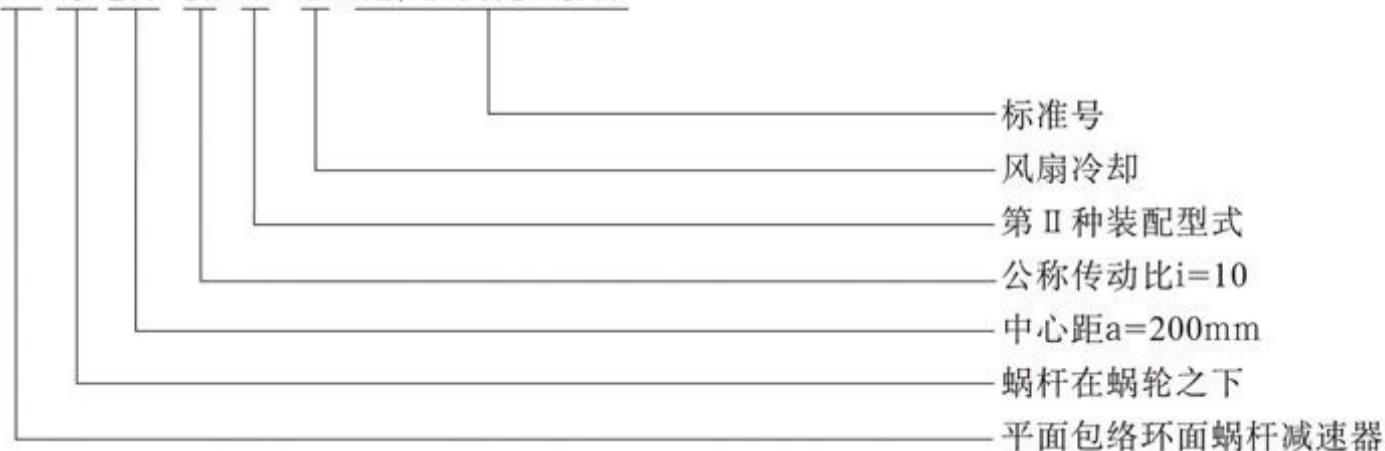

# TP系列减速机安装尺寸表



## 3 外形、安装尺寸 >>>>>

TPU型减速器（整箱式）及装配型式

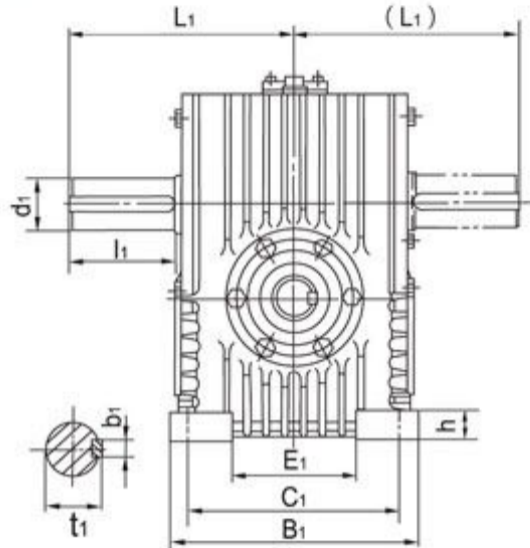
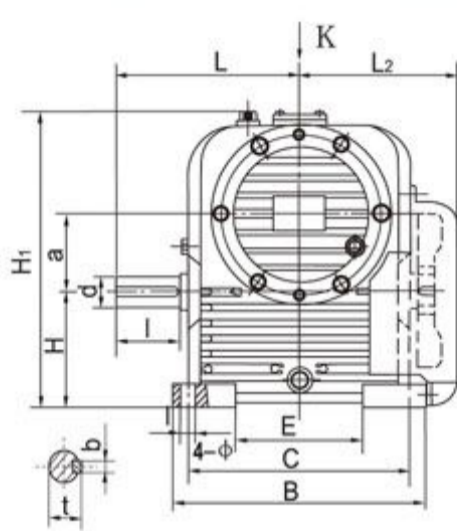

装配型式 (K向)

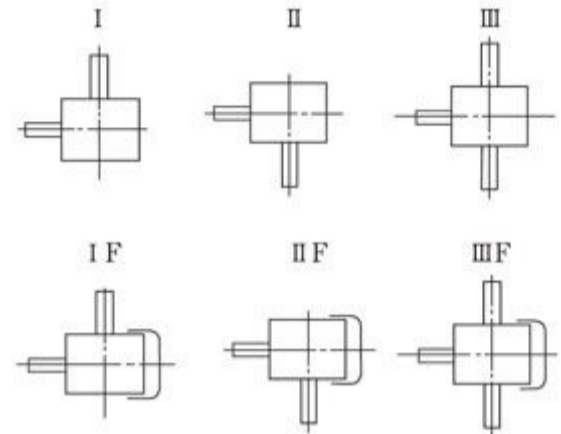

mm

型号	a	B	B <sub>1</sub>	C	C <sub>1</sub>	E	E <sub>1</sub>	H	H <sub>1</sub>	L	L <sub>1</sub>	L <sub>2</sub>	l	l <sub>1</sub>	d	d <sub>1</sub>	b	b <sub>1</sub>	t	t <sub>1</sub>	h	φ	质量kg
TPU100	100	320	260	280	220	160	130	150	382	235	237	200	82	110	40	55	12	16	43	59	30	19	88

TPS型减速器（整箱式）及装配型式

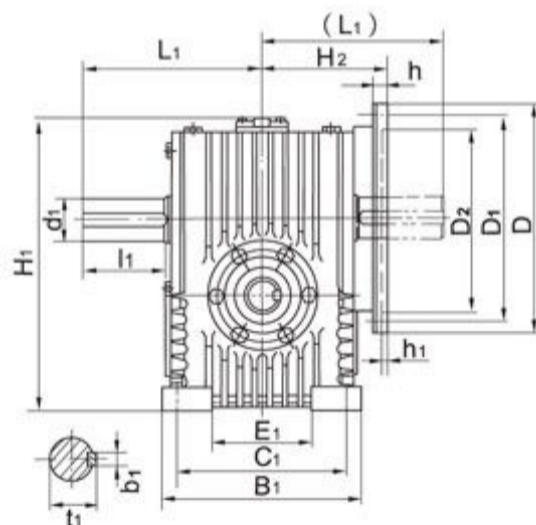
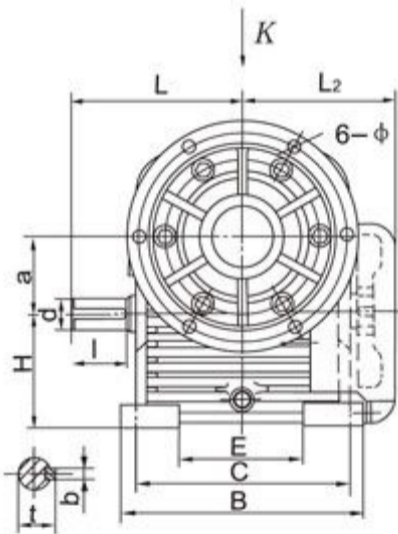

装配型式(K向旋转)

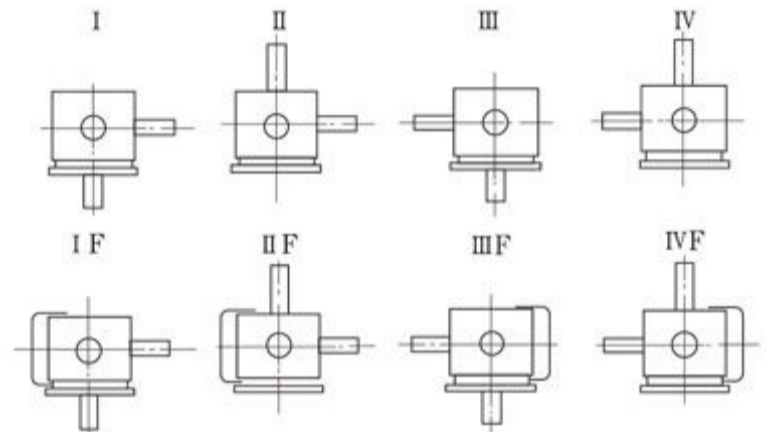

mm

型号	a	B	B <sub>1</sub>	C	C <sub>1</sub>	E	E <sub>1</sub>	H	H <sub>1</sub>	H <sub>2</sub>	L	L <sub>1</sub>	L <sub>2</sub>	l	l <sub>1</sub>	d	d <sub>1</sub>	b	b <sub>1</sub>	t	t <sub>1</sub>	D	D <sub>1</sub>	D <sub>2</sub>	φ	h	h <sub>1</sub>	质量kg
TPS100	100	320	260	280	220	160	130	150	382	160	235	237	200	82	110	40	55	12	16	43	59	300	275	240	14	16	6	90

TPA型减速器（整箱式）及装配型式

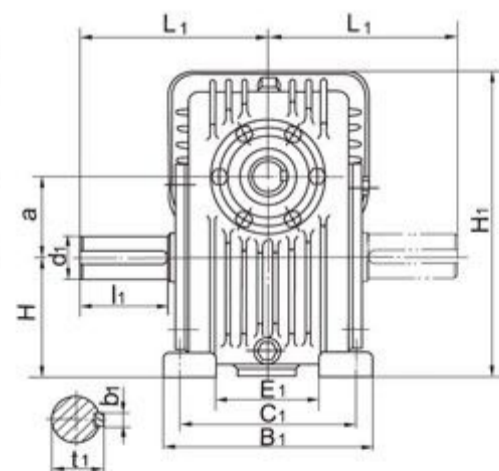
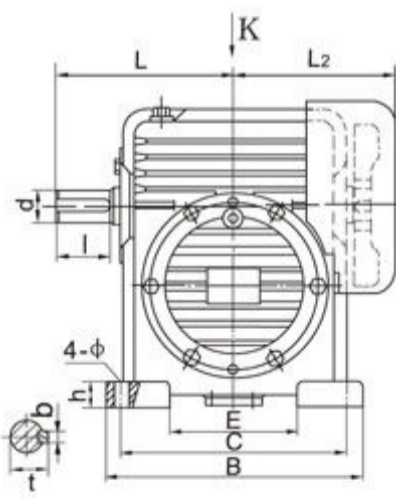

装配型式(K向)

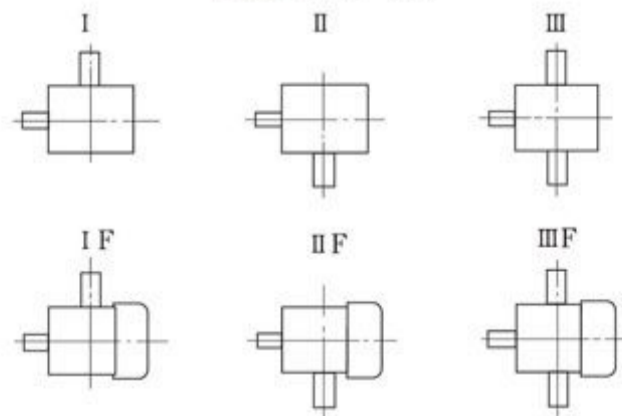

mm

型号	a	B	B <sub>1</sub>	C	C <sub>1</sub>	E	E <sub>1</sub>	H	H <sub>1</sub>	L	L <sub>1</sub>	L <sub>2</sub>	l	l <sub>1</sub>	d	d <sub>1</sub>	b	b <sub>1</sub>	t	t <sub>1</sub>	h	φ	质量kg
TPA100	100	320	260	280	220	160	130	150	389	235	237	200	82	110	40	55	12	16	43	59	30	19	88

## TPU型减速器（分箱式）及装配型式

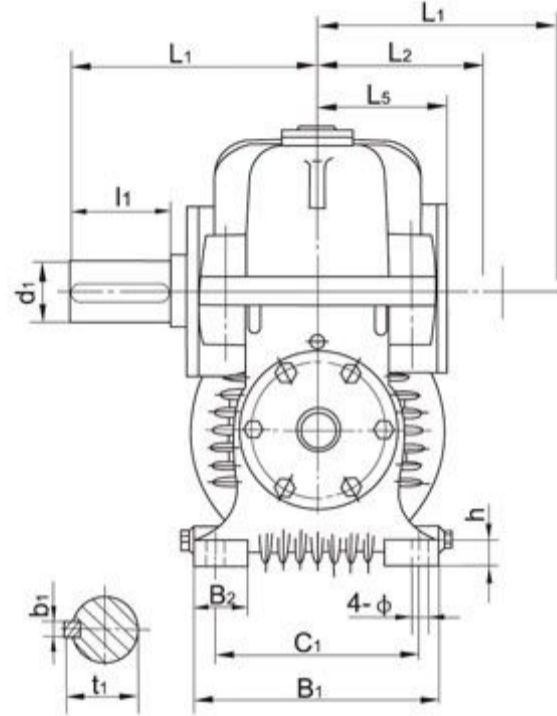
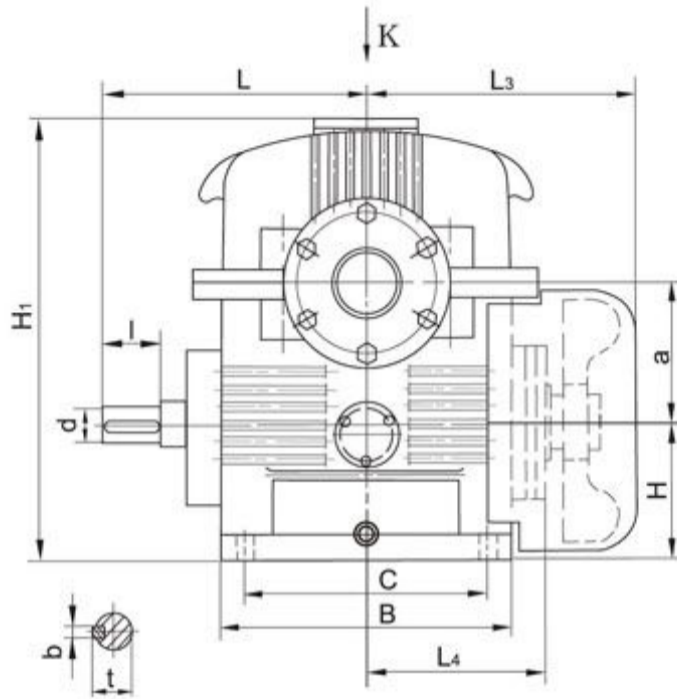

装配型式K向F-带风扇

Ⅲ、ⅢF、Ⅳ、ⅣF带控制器用轴端

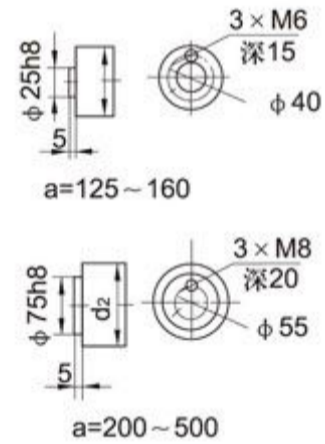
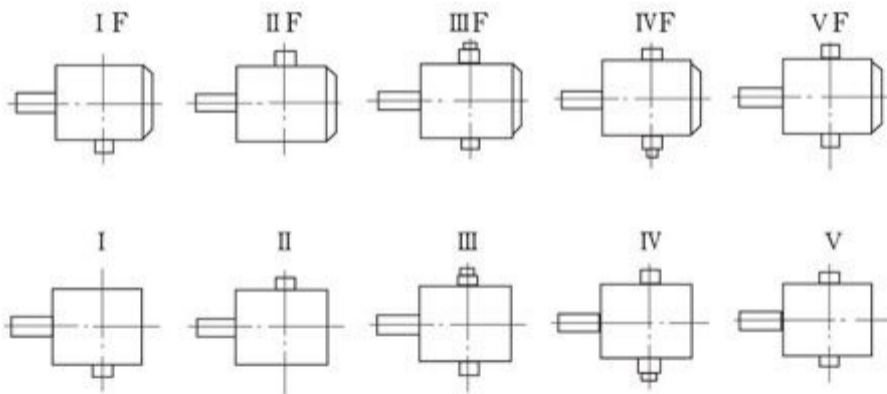

型号	a	B	B <sub>1</sub>	B <sub>2</sub>	C	C <sub>1</sub>	H	H <sub>1</sub>	h	L	L <sub>1</sub>	L <sub>2</sub>	L <sub>3</sub>	L <sub>4</sub>	L <sub>5</sub>	l	l <sub>1</sub>	d	d <sub>1</sub>	d <sub>2</sub>	b	b <sub>1</sub>	t	t <sub>1</sub>	φ	重量 kg
TPU125	125	300	300	70	250	250	125	422	30	307	320	185	280	205	175	82	140	40	70	80	12	20	43	74.5	19	157
TPU160	160	380	375	100	320	310	160	540	40	375	375	210	360	280	192	82	170	50	85	95	14	25	53.5	90	24	258
TPU200	200	450	450	125	370	370	200	650	40	420	400	235	435	345	228	82	170	55	95	110	16	28	59	101	28	475
TPU250	250	600	550	150	500	450	225	820	50	530	495	290	520	408	273	110	210	65	120	140	18	32	69	127	35	800
TPU315	315	720	590	120	630	500	280	990	65	630	600	360	605	492	349	130	250	80	140	160	22	36	85	148	39	1450
TPU400	400	850	720	160	750	620	320	1200	75	720	720	425	692	558	412	165	300	100	180	200	28	45	106	190	48	2500
TPU500	500	1060	900	200	920	760	400	1490	90	850	840	495	845	686	497	165	350	110	220	240	32	45	117	210	56	4500

## TPS型减速器（分箱式）及装配型式

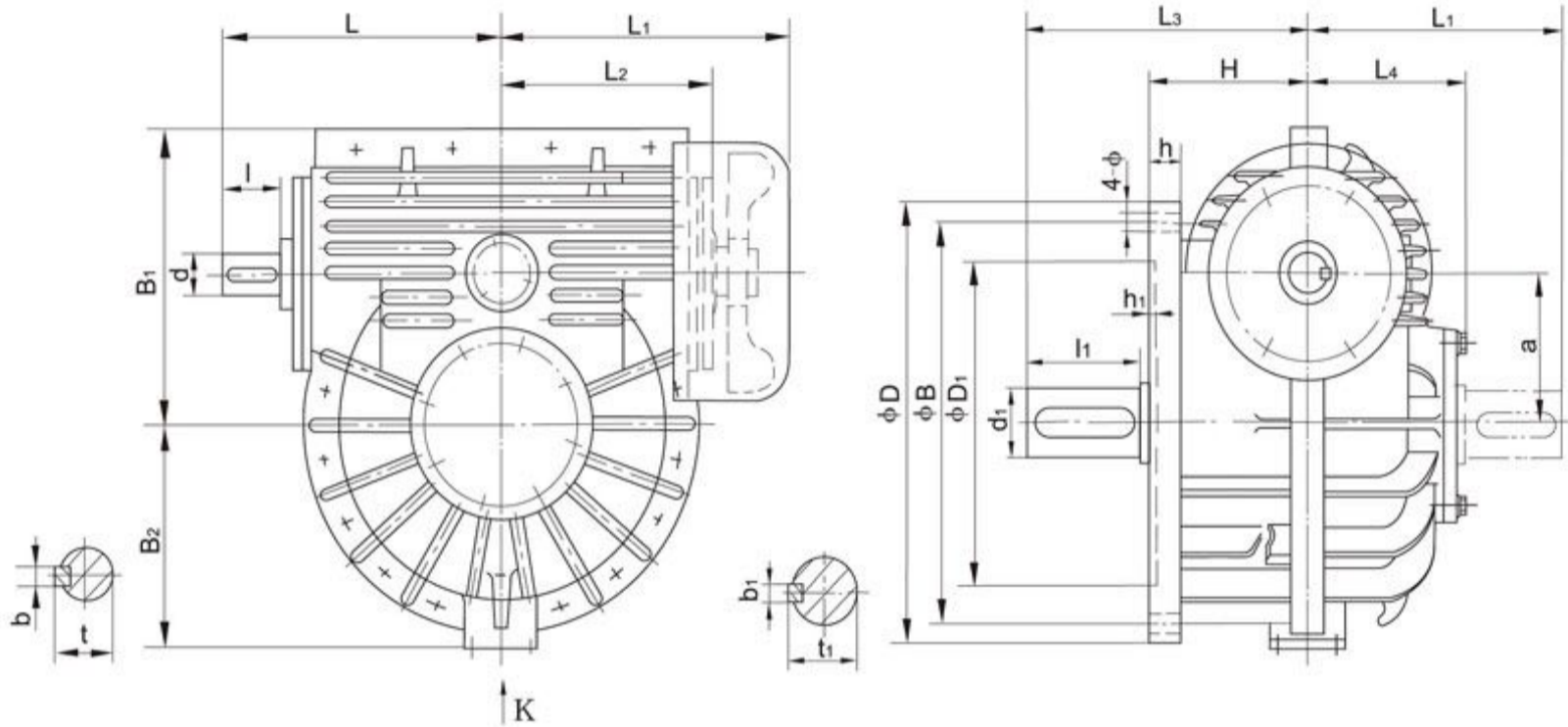

装配型式K向F-带风扇

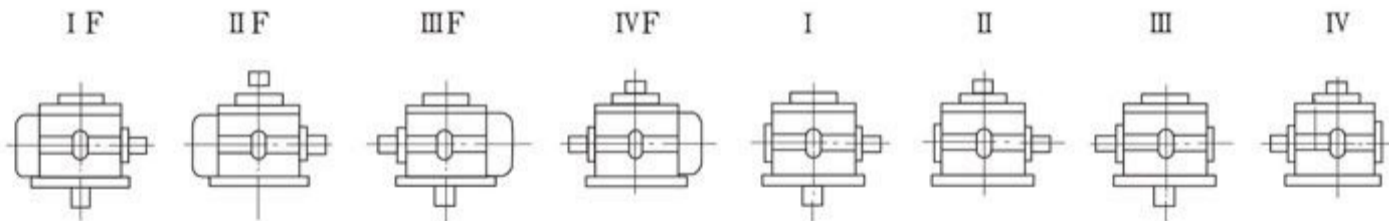

型号	a	D	D <sub>1</sub>	h <sub>1</sub>	B	B <sub>1</sub>	B <sub>2</sub>	H	L	L <sub>1</sub>	L <sub>2</sub>	L <sub>3</sub>	L <sub>4</sub>	l	l <sub>1</sub>	d	d <sub>1</sub>	b	b <sub>1</sub>	t	t <sub>1</sub>	h	φ	重量 kg
TPS125	125	380	280	6	330	265	193	180	307	280	209	320	175	82	140	40	70	12	20	43	74.5	25	19	170
TPS160	160	530	380	10	470	330	265	200	375	365	280	375	192	82	170	50	85	14	25	53.5	90	35	24	290
TPS200	200	650	480	10	580	400	325	250	420	436	336	400	228	82	170	55	95	16	28	59	101	40	32	530
TPS250	250	800	600	12	700	495	400	280	530	520	408	495	273	110	210	65	120	18	32	69	127	50	35	930
TPS315	315	920	710	15	820	625	460	355	630	605	497	600	349	130	250	80	140	22	36	85	148	65	39	1650
TPS400	400	1100	850	15	1000	740	550	420	720	692	558	720	412	165	300	100	180	28	45	106	190	75	48	2800
TPS500	500	1340	1060	20	1200	920	675	530	850	845	686	840	497	165	350	110	220	32	45	117	210	90	56	4800

## TPA型减速器（分箱式）及装配型式

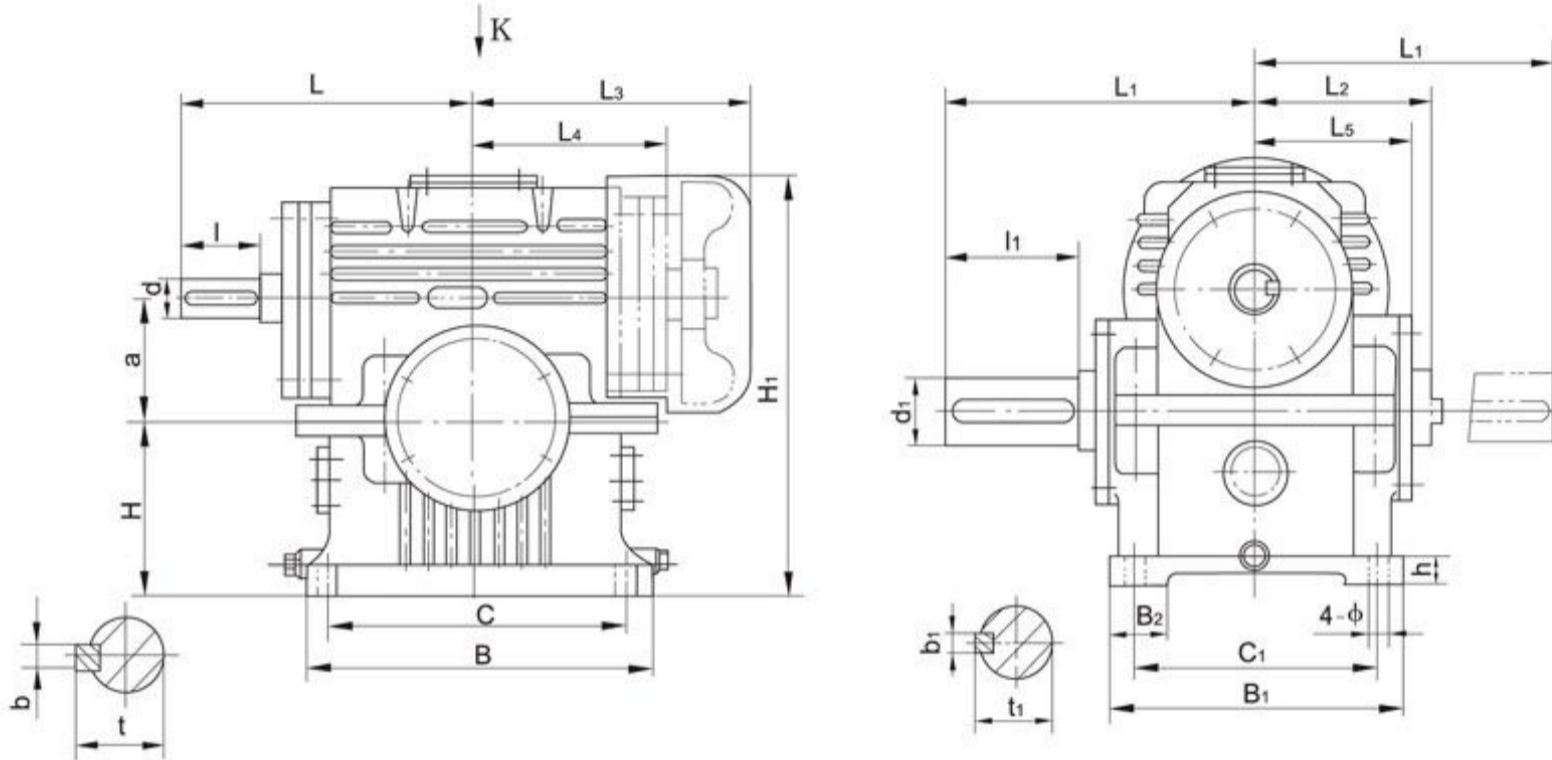

装配型式K向F-带风扇

Ⅲ、ⅢF、Ⅳ、ⅣF带控制器用轴端

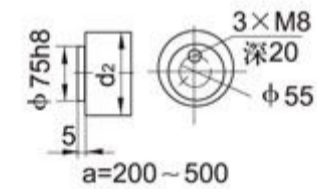
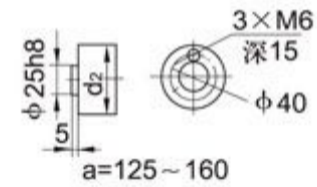
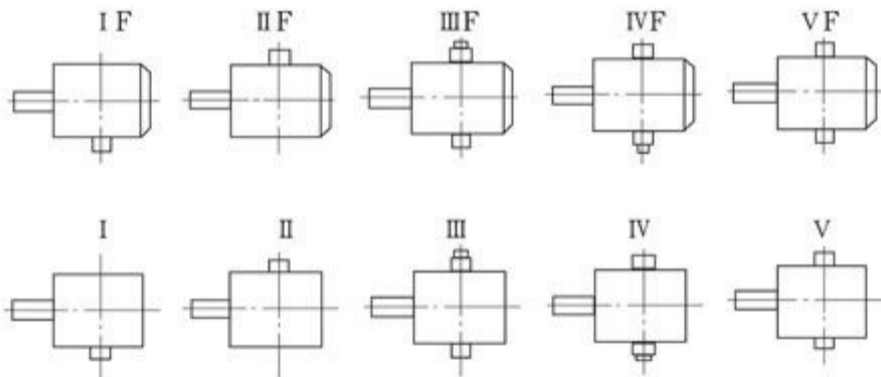

mm

型号	a	B	B <sub>1</sub>	B <sub>2</sub>	C	C <sub>1</sub>	H	H <sub>1</sub>	h	L	L <sub>1</sub>	L <sub>2</sub>	L <sub>3</sub>	L <sub>4</sub>	L <sub>5</sub>	l	l <sub>1</sub>	d	d <sub>1</sub>	d <sub>2</sub>	b	b <sub>1</sub>	t	t <sub>1</sub>	φ	重量 kg
TPA125	125	360	300	50	310	250	180	438	30	307	320	185	280	205	175	82	140	40	70	80	12	20	43	74.5	19	165
TPA160	160	460	320	80	400	260	225	550	40	375	375	210	365	280	190	82	170	50	85	95	14	25	53.5	90	24	285
TPA200	200	540	400	100	450	320	250	658	40	420	400	235	436	345	228	82	170	55	95	110	16	28	59	101	28	510
TPA 0	250	720	480	120	620	380	315	792	50	530	495	290	520	406	270	110	210	65	120	140	18	32	69	127	35	900
TPA315	315	850	600	140	750	500	400	1000	65	630	600	360	605	492	345	130	250	80	140	160	22	36	85	148	39	1550
TPA400	400	950	720	170	850	620	500	1200	75	720	720	425	690	540	410	165	300	100	180	200	28	45	106	190	48	2650
TPA500	500	1180	900	200	1040	760	630	1530	90	850	840	495	845	680	488	165	350	110	220	240	32	45	117	210	56	4700

# TP系列减速机选型参数表



## 4 输入功率与输出转矩 >>>>>

TP系列蜗杆减速器输入功率及输出转矩表

中心距 a/mm	传动比 i	输入轴转速 $n_1/r \cdot \min$														
		500			600			750			1000			1500		
		P <sub>1</sub> (kw)	T <sub>2</sub> (N·m)	n(%)	P <sub>1</sub> (kw)	T <sub>2</sub> (N·m)	n(%)	P <sub>1</sub> (kw)	T <sub>2</sub> (N·m)	n(%)	P <sub>1</sub> (kw)	T <sub>2</sub> (N·m)	n(%)	P <sub>1</sub> (kw)	T <sub>2</sub> (N·m)	n(%)
100	10.0	7.34	1262	90	8.17	1171	90	9.25	1083	92	10.64	945	93	11.73	695	93
	12.5	5.76	1225	89	6.53	1156	89	7.53	1091	91	8.90	977	92	10.30	754	92
	16.0	4.94	1313	87	5.58	1250	88	6.42	1178	90	7.56	1052	91	8.71	807	91
	20.0	4.05	1268	85	4.60	1215	86	5.32	1124	86	6.30	1047	87	7.33	822	88
	25.0	3.29	1306	83	3.75	1252	84	4.34	1188	86	5.16	1071	87	6.03	835	87
	31.5	2.74	1271	77	3.10	1214	78	3.58	1176	82	4.22	1053	83	4.87	810	83
	40.0	2.12	1199	74	2.42	1157	75	2.82	1120	78	3.37	1016	79	3.98	800	79
	50.0	1.77	1203	71	2.02	1171	73	2.33	1114	75	2.77	1003	76	3.22	780	76
	63.0	1.44	1177	68	1.69	1172	69	1.99	1148	72	2.31	1013	73	2.60	762	73
125	10.0	12.55	2157	90	13.97	2001	90	15.81	1852	92	18.20	1617	93	20.09	1190	93
	12.5	9.86	2096	89	11.17	1979	89	12.89	1868	91	15.23	1673	92	17.65	1292	92
	16.0	8.46	2248	87	9.55	2141	88	10.99	2016	90	12.94	1800	91	14.89	1380	91
	20.0	6.93	2169	85	7.86	2077	86	9.09	1922	86	10.77	1790	87	12.55	1406	88
	25.0	5.64	2236	83	6.41	2143	84	7.43	2033	86	8.82	1831	87	10.30	1427	87
	31.5	4.70	2178	77	5.32	2080	78	6.13	2016	82	7.23	1805	83	8.34	1389	83
	40.0	3.64	2059	74	4.16	1985	75	4.84	1921	78	5.77	1742	79	6.81	1371	79
	50.0	3.05	2068	71	3.46	2011	73	4.00	1911	75	4.74	1721	76	5.52	1335	76
	63.0	2.47	2020	68	2.91	2012	69	3.41	1971	72	3.96	1740	73	4.47	1308	73
160	10.0	22.58	3928	90	25.41	3641	90	28.75	3368	92	33.06	2936	93	36.41	2156	93
	12.5	17.95	3815	89	20.32	3598	89	23.42	3392	91	27.63	3035	92	31.93	2338	92
	16.0	15.30	4068	87	17.30	3876	88	19.92	3652	90	23.46	3262	91	27.03	2506	91
	20.0	12.55	3930	85	14.26	3766	86	16.50	3488	86	19.58	3253	87	22.85	2560	88
	25.0	10.20	4043	83	11.61	3881	84	13.46	3686	86	16.01	3326	87	18.77	2599	87
	31.5	8.53	3950	77	9.64	3771	78	11.11	3653	82	13.09	3269	83	15.10	2513	83
	40.0	6.61	3737	74	7.54	3601	75	8.77	3484	78	10.47	3159	79	12.34	2483	79
	50.0	5.53	3749	71	6.28	3646	73	7.26	3466	75	8.60	3122	76	10.02	2423	76
	63.0	4.48	3664	68	5.28	3650	69	6.19	3575	72	7.18	3155	73	8.10	2371	73
200	10.0	39.07	6715	90	43.47	6227	90	49.20	5764	92	56.60	5027	93	62.42	3696	93
	12.5	30.70	6524	89	34.76	6156	89	40.10	5808	91	47.34	5199	92	54.77	4010	92
	16.0	26.32	6997	87	29.74	6665	88	34.23	6277	90	40.31	5605	91	46.41	4302	91
	20.0	21.52	6742	85	24.44	6458	86	28.28	5977	86	33.52	5570	87	39.07	4377	88
	25.0	17.54	6953	83	19.95	6669	84	23.12	6330	86	27.47	5706	87	32.13	4449	87
	31.5	14.59	6757	77	16.50	6454	78	19.02	6256	82	22.43	5602	83	25.91	4313	83
	40.0	11.32	6401	74	12.93	6173	75	15.04	5975	78	17.97	5422	79	21.22	4268	79
	50.0	9.50	6439	71	10.77	6259	73	12.45	5945	75	14.74	5349	76	17.14	4146	76
	63.0	7.67	6276	68	9.04	6252	69	10.60	6123	72	12.31	5405	73	13.87	4062	73



TP系列蜗杆减速器输入功率及输出转矩续表

中心距 a/mm	传动比 i	输入轴转速 $n_1/r \cdot \min$														
		500			600			750			1000			1500		
		P <sub>1</sub> (kw)	T <sub>2</sub> (N·m)	n(%)	P <sub>1</sub> (kw)	T <sub>2</sub> (N·m)	n(%)	P <sub>1</sub> (kw)	T <sub>2</sub> (N·m)	n(%)	P <sub>1</sub> (kw)	T <sub>2</sub> (N·m)	n(%)	P <sub>1</sub> (kw)	T <sub>2</sub> (N·m)	n(%)
250	10.0	67.01	11776	92	74.57	10920	92	84.41	10103	94	97.11	8810	95	107.10	6478	95
	12.5	52.53	11413	91	59.49	10772	91	68.64	10160	93	81.06	9096	94	93.84	7020	94
	16.0	45.08	12262	89	50.95	11677	90	58.64	10991	92	69.03	9810	93	79.46	7528	93
	20.0	36.92	12271	87	41.93	11746	88	48.51	10871	88	57.51	9776	89	67.01	7680	90
	25.0	30.09	12213	85	34.22	11710	86	39.65	11107	88	47.10	10008	89	55.08	7803	89
	31.5	24.99	11878	79	28.29	11345	80	32.61	10987	84	38.48	9839	85	44.47	7581	85
	40.0	19.38	11253	76	22.13	10847	77	25.74	10490	80	30.75	9516	81	36.31	7490	81
	50.0	16.32	11377	73	18.51	11046	75	21.38	10481	77	25.30	9421	78	29.38	7294	78
	63.0	13.16	11083	70	15.50	11034	71	18.18	10791	74	21.09	9518	75	23.77	7149	75
315	10.0	117.30	20612	92	130.45	19102	92	148.10	17727	94	169.58	15385	95	187.20	11322	95
	12.5	99.96	21718	91	108.20	19590	91	120.00	17763	93	141.78	15909	94	164.22	12285	94
	16.0	83.90	22819	89	91.88	21059	90	102.80	19268	92	120.54	17130	93	138.72	13142	93
	20.0	65.10	21635	87	73.23	20516	88	84.76	18996	88	100.55	17093	89	117.30	13443	90
	25.0	53.45	21694	85	59.74	20444	86	69.22	19391	88	82.24	17474	89	96.19	13626	89
	31.5	44.94	21360	79	49.50	19855	80	57.04	19217	84	67.5	17197	85	77.62	13232	85
	40.0	33.86	19663	76	38.66	18954	77	44.98	18330	80	53.73	16626	81	63.44	13087	81
	50.0	28.46	19839	73	32.29	19273	75	37.33	18298	77	44.20	16463	78	51.41	12765	78
	63.0	23.63	19904	70	27.04	19250	71	31.72	18831	74	36.82	16615	75	41.51	12488	75
400	10.0	222.20	39045	92	257.40	37692	92	276.90	33143	94	311.00	28215	95	359.90	21768	95
	12.5	193.20	41975	91	215.30	38981	91	236.30	34978	93	262.50	29456	94	304.50	22779	94
	16.0	170.00	46237	89	183.80	42127	90	203.70	38180	92	230.00	32682	93	264.60	25067	93
	20.0	131.30	43636	87	141.80	39723	88	156.50	35073	88	177.50	30173	89	200.60	22989	90
	25.0	105.00	42617	85	114.50	39183	86	128.10	35885	88	144.90	30789	89	164.90	23359	89
	31.5	88.52	42074	79	96.92	38875	80	107.10	36085	84	121.80	31144	85	138.60	23627	85
	40.0	66.57	38653	76	72.24	35414	77	80.85	32944	80	91.98	28460	81	104.70	21598	81
	50.0	53.55	37332	73	58.70	35037	75	65.21	31968	77	74.03	27572	78	84.11	20885	78
	63.0	46.41	39092	70	51.14	36409	71	56.70	33659	74	64.37	29046	75	73.19	22017	75
500	10.0	393.90	69216	92	424.40	62146	92	462.50	55358	94	511.50	46406	95	582.50	35232	95
	12.5	329.70	71631	91	361.20	65396	91	395.90	58603	93	432.60	48543	94	486.20	36372	94
	16.0	286.70	77978	89	306.60	70273	90	340.20	63765	92	382.20	54312	93	431.60	40888	93
	20.0	218.40	72583	87	240.50	67372	88	263.60	59075	88	293.00	49807	89	326.60	37428	90
	25.0	180.60	73301	85	198.50	67928	86	219.50	61489	88	243.60	51762	89	278.30	39424	89
	31.5	152.30	72389	79	164.90	66141	80	183.80	61927	84	206.90	52905	85	233.10	39736	85
	40.0	114.50	66483	76	126.0	61769	77	138.60	56475	80	154.40	47774	81	176.40	36388	81
	50.0	92.82	64709	73	101.40	60523	75	112.40	55102	77	123.90	46147	78	141.80	35209	78
	63.0	80.85	68101	70	88.31	62873	71	97.34	57784	74	108.20	48824	75	122.90	36971	75



## 格鲁夫产品>>应用案例

### APPLICATION CASE

从核心产业到环境生活, **GELUFU** 齿轮减速电机以其超凡可靠性和耐久性在各个领域赢得了广泛的信誉。

**GELUFU** 拥有在与主要客户的紧密合作中发展起来的应用技术和工程设计, 通晓齿轮电机的应用条件, 为您的驱动应用提供先进并且经济的选择。

**GELUFU** 的经营理念是视产品应用与周到的服务于一体, 这一态度为我们与用户奠定了良好的合作基础, 从而导致卓有成效, 牢固长久的共同繁荣。



输送设备



异型材牵引机



模具设备



三辊压光机



环保设备



物流设备



挤出设备



定量给料机



烟草设备



饮料设备



管材设备



烟草设备



## **格鲁夫机械设备制造有限公司**

Gelufu Machinery Equipment Manufacturing Co. Ltd

地址 (ADD) : 河北•保定 邮编 (P.C) : 071000

电话 (TEL) : +86-312-6784766

传真 (FAX) : +86-312-6784733

<http://www.gelufu.com>

E-mail: [china@gelufu.com](mailto:china@gelufu.com)

